

SK2-622D Catch Basin w/ Polymer Concrete Base

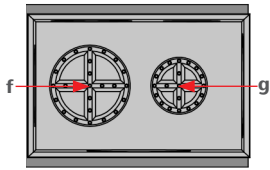

SK2-622D
part no. 97923 (S200K)

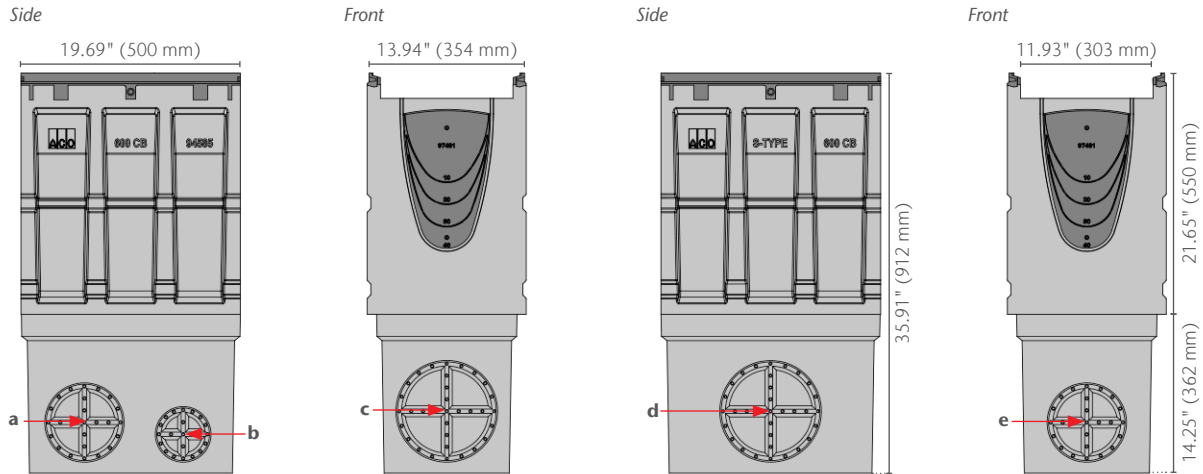

Catch Basin Outlet	Size (SCH 40)	Invert in	GPM	CFS
a	6.00"	34.41	686	2.58
b	4.00"	34.47	310	0.71
c	8.00"	34.41	1200	2.76
d	8.00"	34.41	1200	2.76
e	6.00"	34.41	686	2.58
f	6.00"	35.90	734	1.69
g	4.00"	35.90	326	0.75

Note: These are pipe flow rates at specified outlets, NOT channel flow rates. Catch basin flow rates are listed without a trash bucket—using a trash bucket reduces flow.

Trash Bucket

included with SK2-622D

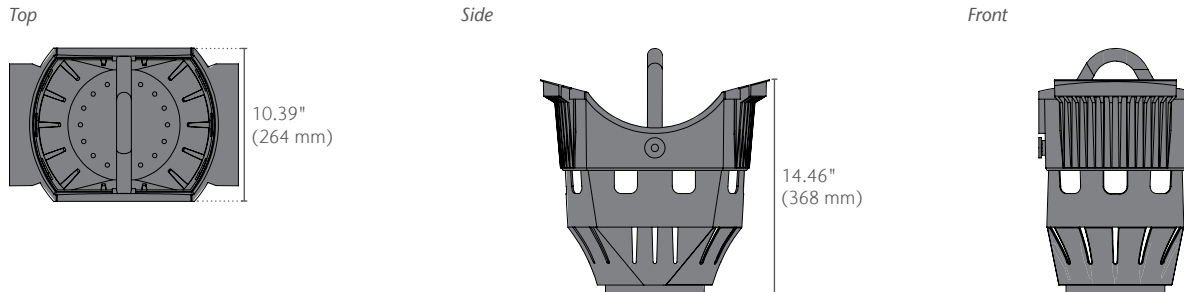

SK2-622D Catch Basin w/ Polymer Concrete Base



Product Name	Part No.	Volume* gal	Weight lbs
SK2-622D Catch Basin w/ Polymer Concrete Base	97923	32.1	169.0

*Volume is up to grate seat and without trash bucket.

Specification Summary

General

The catch basin shall be ACO Drain® SK2-622D Catch Basin, comprising of a top section, trash bucket and base as manufactured by ACO, Inc. or similar approved.

Grates

Grates shall be specified. See separate ACO Spec Info grate sheets for details. After removal of grates there shall be uninterrupted access to the catch basin to aid maintenance. Accepts all 0.5 m ACO S200K PowerLok® grates or S200K 4-Bolt grates.

Installation

The trench drain/catch basin system shall be installed in accordance with the manufacturer's installation instructions and recommendations.

Materials

The catch basin top section and base shall be manufactured from polymer concrete with the minimum properties as follows:

- Compressive strength: 13,053 psi
- Flexural strength: 3,191 psi
- Water absorption: 0.07%
- Resistant to dilute acid and alkali
- Frost-proof
- Salt-proof

The nominal clear opening shall be 11.93" (303 mm) wide by 19.69" (500 mm) long. Type SK2-622D catch basin assembly has overall depth of 35.91" (912 mm). Polymer concrete top units shall incorporate a cast in a ductile iron frame manufactured with drillouts for channel connection and have a wall thickness of at least 0.59" (15 mm). Top units shall have horizontal cast in anchoring key features on the outside to ensure maximum mechanical bond to the surrounding bedding material and pavement surface. The trash bucket shall be a polypropylene plastic molding



200,000 lb Proof Load



EN1433 Load Class F
202,328 lbs – 4,177 psi

ACO, Inc.

© January 2026 ACO, Inc.

All reasonable care has been taken in compiling the information in this document. All recommendations and suggestions on the use of ACO products are made without guarantee since the conditions of use are beyond the control of the company. It is the customer's responsibility to ensure that each product is fit for its intended purpose and that the actual conditions of use are suitable. ACO, Inc. reserves the right to change products and specifications without notice.

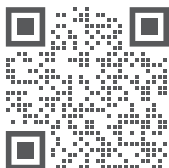

info@acousa.com
www.acousa.com

